

THIS DRAWING IS UNPUBLISHED. RELEASED FOR PUBLICATION
 © COPYRIGHT BY TYCO ELECTRONICS CORPORATION. ALL RIGHTS RESERVED.

LOC	DIST	REVISIONS					
FT	0	P	LTR	DESCRIPTION	DATE	DWN	APVD
			D	REVISED PER ECO-05-10413	9/29/05	SS	SRY

SPECIFICATIONS:
D-SUB CONNECTOR:

MATERIALS:
 HOUSING: THERMOPLASTIC POLYESTER, 94V-0.
 CONTACTS: COPPER ALLOY, GOLD OVER NICKEL
MECHANICAL:
 WIRE RANGE: 26-30 AWG SOLID, 28 AWG STRANDED

TERMINAL BLOCK:

MATERIALS:
 HOUSING: THERMOPLASTIC NYLON, BLACK, 94V-0.
 TERMINALS: COPPER ALLOY, BRIGHT ACID-TIN OVER COPPER PLATED.
 SCREWS: 3M, BRASS, NICKEL PLATED.

ELECTRICAL:
 RATING: 10A, 300V, 
MECHANICAL:
 WIRE RANGE: 14-22 AWG.

MOUNTING:

MATERIALS: RIGID PVC, GRAY.
MOUNTING: 2TK2 AND 2TK2D SERIES SNAPTRACK, (SOLD SEPARATELY).

 CONTAINS NO TIN-LEAD PLATING.

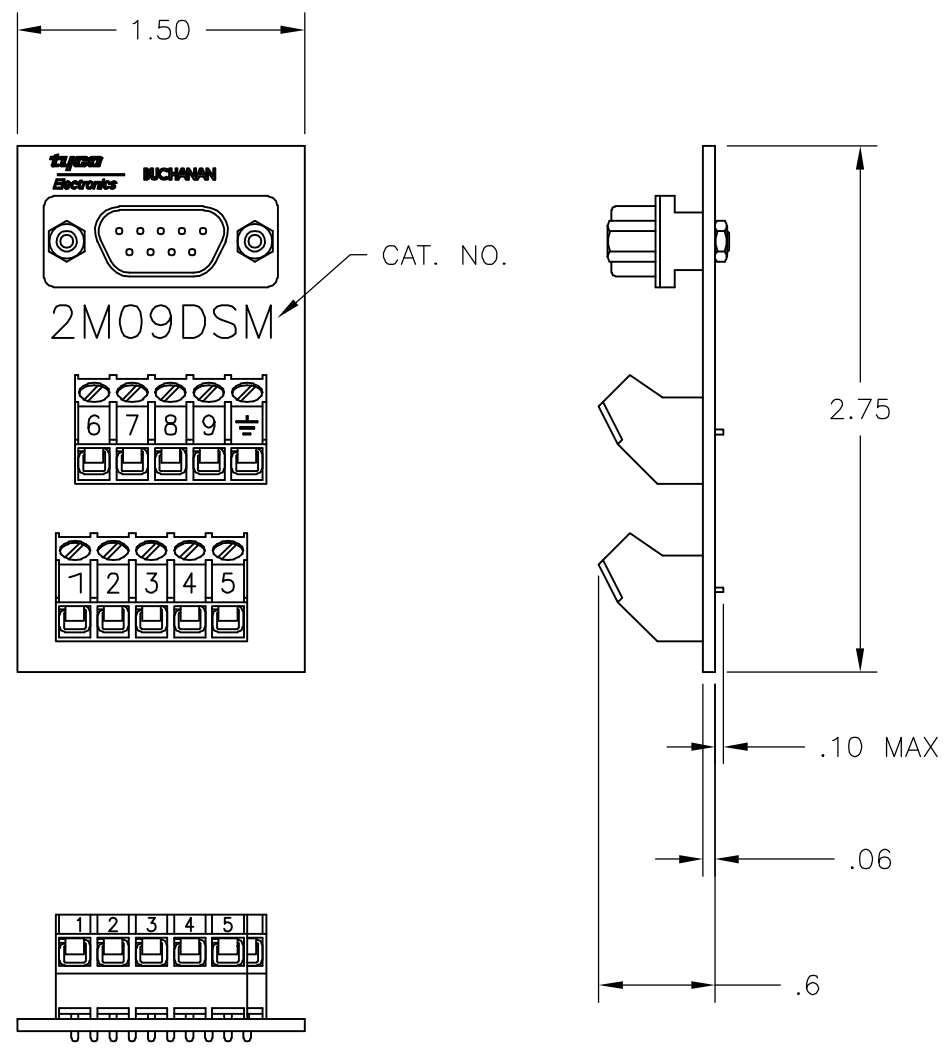

	2M09DSML	1546693-1
	2M09DSM	1437684-3
	CATALOG NO.	PART NUMBER

THIS DRAWING IS A CONTROLLED DOCUMENT.		DWN	S SCHLEGEL	08JUL02	 Tyco Electronics Corporation Harrisburg, PA 17105-3608		
DIMENSIONS: INCHES		CHK	H. WAKEEM	7/8/02			
TOLERANCES UNLESS OTHERWISE SPECIFIED:		APVD	H. WAKEEM	7/8/02	NAME		
0 PLC ± -		PRODUCT SPEC		2M09DSM ASSEMBLY			
1 PLC ± .1		APPLICATION SPEC		-			
2 PLC ± .01		SIZE	A3	CAGE CODE	00779	DRAWING NO	C-1437684-3
3 PLC ± -		WEIGHT		RESTRICTED TO			
4 PLC ± -		-		-			
ANGLES ± -		CUSTOMER DRAWING		SCALE	NTS	SHEET	1 of 1
FINISH		-		REV		D	